



US010901695B1

(12) **United States Patent**
Tatarkiewicz et al.

(10) **Patent No.:** **US 10,901,695 B1**
(45) **Date of Patent:** **Jan. 26, 2021**

(54) **APPARATUS, SYSTEMS, AND METHODS FOR BETA DECAY BASED TRUE RANDOM NUMBER GENERATOR**

(71) Applicants: **Jan Jakub Tatarkiewicz**, San Diego, CA (US); **Janusz Jerzy Borodzinski**, Warsaw (PL); **Wieslaw Bohdan Kuzmicz**, Warsaw (PL)

(72) Inventors: **Jan Jakub Tatarkiewicz**, San Diego, CA (US); **Janusz Jerzy Borodzinski**, Warsaw (PL); **Wieslaw Bohdan Kuzmicz**, Warsaw (PL)

(73) Assignee: **RANDAEMON SP. Z O.O.**, Warsaw (PL)

(*) Notice: Subject to any disclaimer, the term of this patent is extended or adjusted under 35 U.S.C. 154(b) by 0 days.

(21) Appl. No.: **16/990,087**

(22) Filed: **Aug. 11, 2020**

Related U.S. Application Data

(60) Provisional application No. 62/984,528, filed on Mar. 3, 2019, provisional application No. 63/062,672, filed on Aug. 7, 2020.

(51) **Int. Cl.**
G06F 7/58 (2006.01)

(52) **U.S. Cl.**
CPC **G06F 7/588** (2013.01)

(58) **Field of Classification Search**
CPC G06F 7/588
See application file for complete search history.

(56) **References Cited**

U.S. PATENT DOCUMENTS

3,445,591 A 5/1969 Koehler
3,790,768 A 2/1974 Chevalier

4,527,798 A 7/1985 Siekierski
4,855,690 A 8/1989 Dias
4,905,176 A 2/1990 Schulz
5,570,307 A 10/1996 Takahshi
5,627,894 A 5/1997 Albert
5,732,138 A 3/1998 Noll
5,987,483 A * 11/1999 Edelkind G06F 7/588
708/250
6,249,009 B1 6/2001 Kim
(Continued)

FOREIGN PATENT DOCUMENTS

WO WO-2014080272 A1 * 5/2014 G06F 7/588

OTHER PUBLICATIONS

S. Burri, D. Stucki, Y. Maruyama, C. Bruschini, E. Charbon and F. Regazzoni, "SPADs for quantum random number generators and beyond," 2014 19th Asia and South Pacific Design Automation Conference (ASP-DAC), Singapore, 2014, pp. 788-794, doi: 10.1109/ASPDAC.2014.6742986. (Year: 2014).*

(Continued)

Primary Examiner — Andrew Caldwell
Assistant Examiner — Carlo Waje

(74) *Attorney, Agent, or Firm* — Manuel de la Cerra

(57) **ABSTRACT**

Disclosed herein is a true random number generator (TRNG). The TRNG includes an enclosure defining a cavity and a cap covering the cavity and having a cap surface exposed to the cavity, the cap surface including radioactive nickel. An electronic sensor within a cavity detects electrons from the decay of the nickel and produces a signal for the detected energy. An amplifier is connected to the sensor and is constructed to amplify the signal and then feeds the signal to a filter. A processor connected to the filter generates a true random number based on the signal. This TRNG may be formed on an integrated circuit.

19 Claims, 7 Drawing Sheets

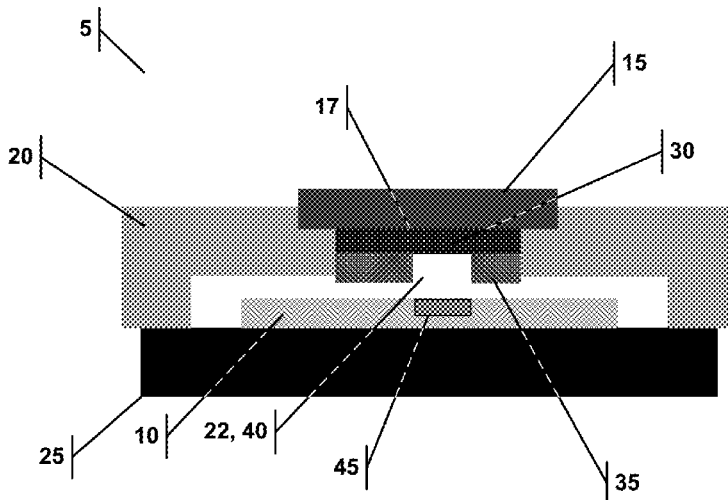

(56)

References Cited

U.S. PATENT DOCUMENTS

8,001,054	B1	8/2001	Peart	
6,346,700	B1	2/2002	Cunningham	
6,415,309	B1 *	7/2002	Shilton	G06F 7/588 708/250
6,430,170	B1	8/2002	Saints	
6,539,410	B1	3/2003	Klass	
6,542,014	B1 *	4/2003	Saito	G06F 7/588 327/164
6,687,721	B1	2/2004	Wells	
6,697,829	B1 *	2/2004	Shilton	H03K 3/84 708/255
6,745,217	B2 *	6/2004	Figotin	G06F 7/588 708/250
7,031,991	B2	4/2006	Hars	
7,124,157	B2	10/2006	Ikake	
7,476,370	B2	1/2009	Mitsugashira	
8,001,168	B2	8/2011	Tsuyuzaki	
8,037,117	B2	10/2011	Saito	
9,335,972	B2	5/2016	Yang	
10,430,161	B1 *	10/2019	Tatarkiewicz	G06F 7/588
2009/0165086	A1 *	6/2009	Trichina	G06F 7/588 726/2
2012/0030268	A1	2/2012	Liu	
2018/0217817	A1	8/2018	Gorfinkle	
2019/0258458	A1 *	8/2019	Walmsley	G06F 7/588
2019/0347076	A1 *	11/2019	Park	G06F 7/588
2020/0065068	A1 *	2/2020	Hekmatshoartabari	H04L 9/0869
2020/0092328	A1 *	3/2020	Kim	H04L 9/088
2020/0210147	A1 *	7/2020	Lee	G06F 7/588

OTHER PUBLICATIONS

Duggirala R., Lal A., Radhakrishnan S. (2010) Radioisotope Decay Rate Based Counting Clock. In: Radioisotope Thin-Film Powered Microsystems. MEMS Reference Shelf, vol. 6. Springer, New York, NY. https://doi.org/10.1007/978-1-4419-6763-3_7 (Year: 2010).*

Collantes et al. "Quantum Random Number Generators", 2016 Retrieved from the Internet <<https://arxiv.org/pdf/1604.03304.pdf>> (Year: 2016).*

Rohe, "RANDy—A True-Random Generator Based on Radioactive Decay", 2003. Retrieved from the Internet <<https://citeseerx.ist.psu.edu/viewdoc/download?doi=10.1.1.110.9725&rep=rep1&type=pdf>> (Year: 2003).*

FIFO Architecture, Functions, and Applications, 1999. Retrieved from the Internet <<https://www.ti.com/lit/an/scaa042a/scaa042a.pdf>> (Year: 1999).*

Advanced Encryption Standard (AES) , 2001. Retrieved from the Internet <<https://nvlpubs.nist.gov/nistpubs/FIPS/NIST.FIPS.197.pdf>> (Year: 2001).*

Jones on "True random number generators for a more secure IoT", Mar. 2016. Retrieved on [Oct. 29, 2020]. Retrieved from the Internet <<https://www.techdesignforums.com/practice/technique/true-random-number-generators-for-more-secure-systems/>> (Year: 2016).*

International Search Report and Written Opinion for PCT/US2019/017748 dated Dec. 30, 2019 (6 pages).

B. Škorić 2015 Lecture notes 2IMS10 Technical University Eindhoven (Holland) Physical aspects of digital security.

D.F. Williams et al. 1993 Oak Ridge National Laboratory TM-12399 Recovery and Purification of Nickel-63 from HFIR-irradiated Targets.

J. von Neumann 1951 Res. Nat. Bur. Stand. Appl. Math. Series 3, 36-38 Various techniques used in connection with random digits.

M.J. Berger and S.M. Seltzer 1982 National Bureau of Standards NBSIR 82-2550 Stopping Powers and Ranges of Electrons and Positrons.

NRC Personal Annual Radiation Dose Calculator <https://www.nrc.gov/aboutnrc/radiation/around-us/calculator.html>.

Patuleanu et al. 2017 Proc. Romanian Acad. series A, vol. 18, 389-402 True random number sequences from gamma-decay using four extraction methods.

* cited by examiner

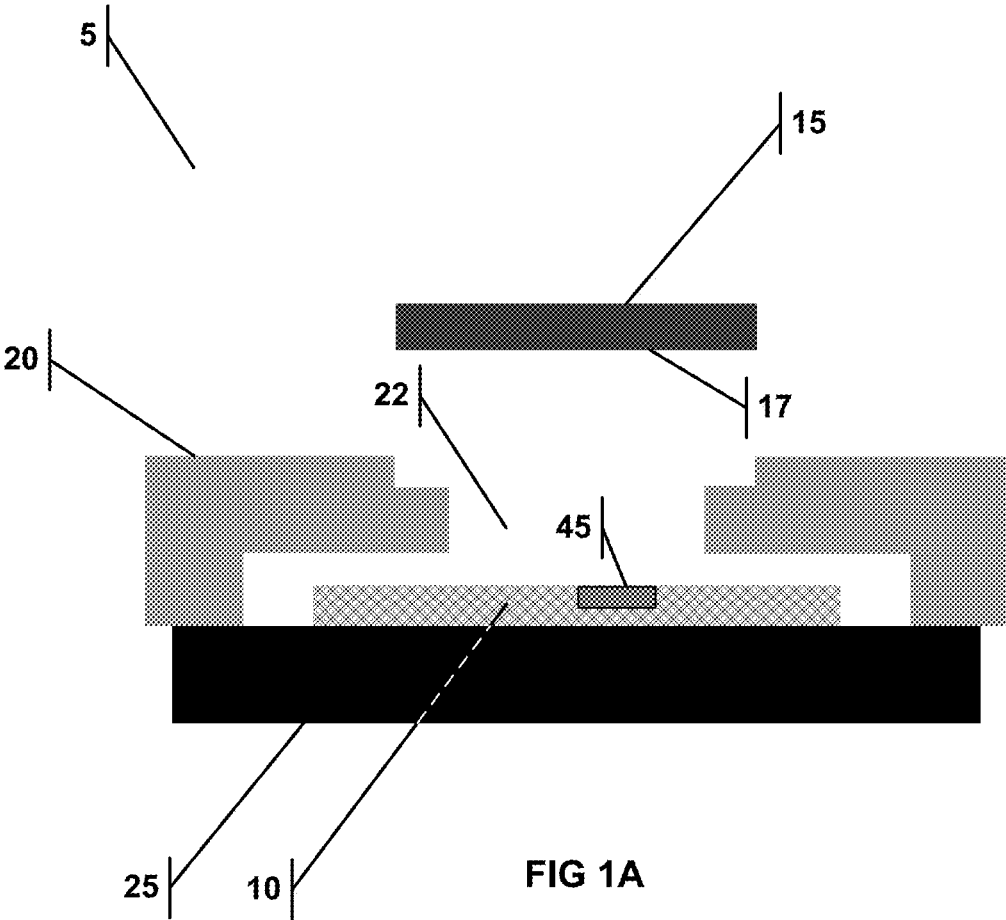

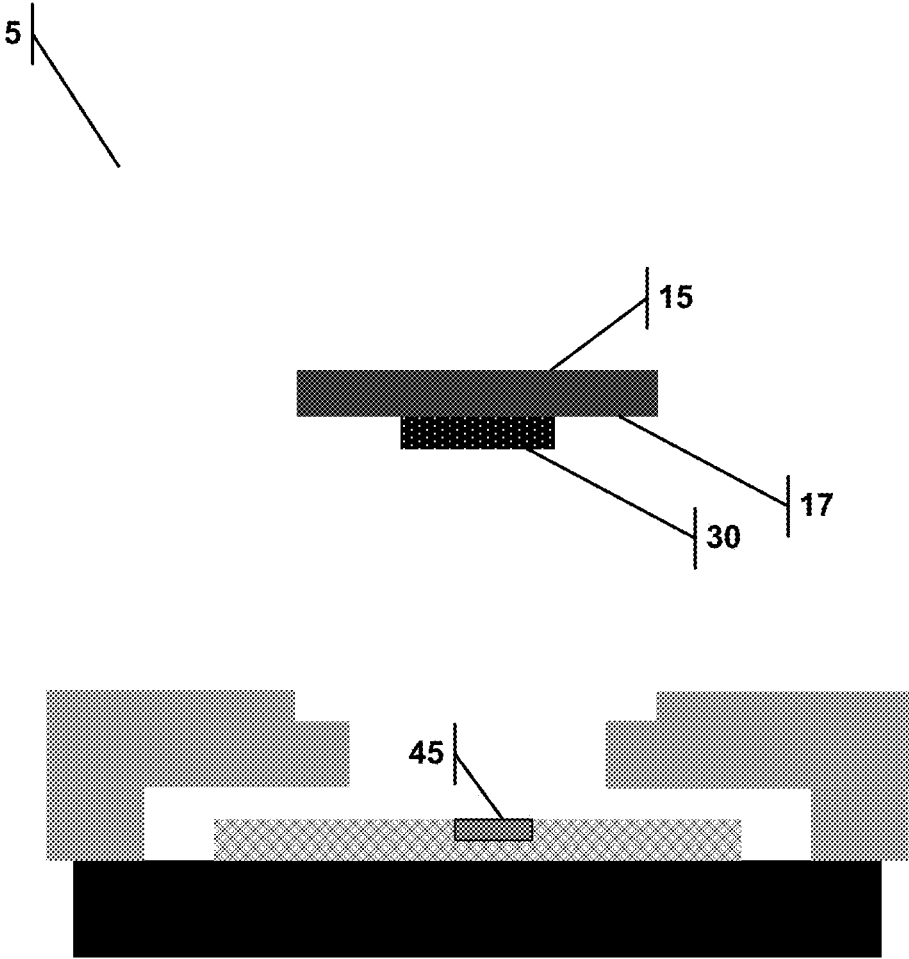

FIG 1B

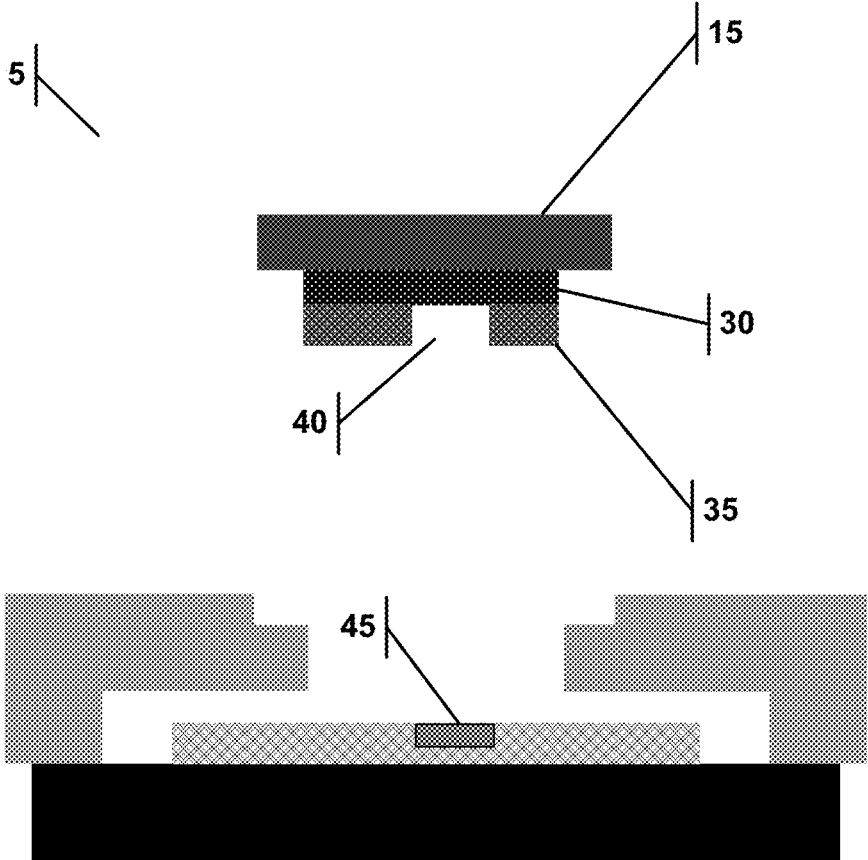

FIG 1C

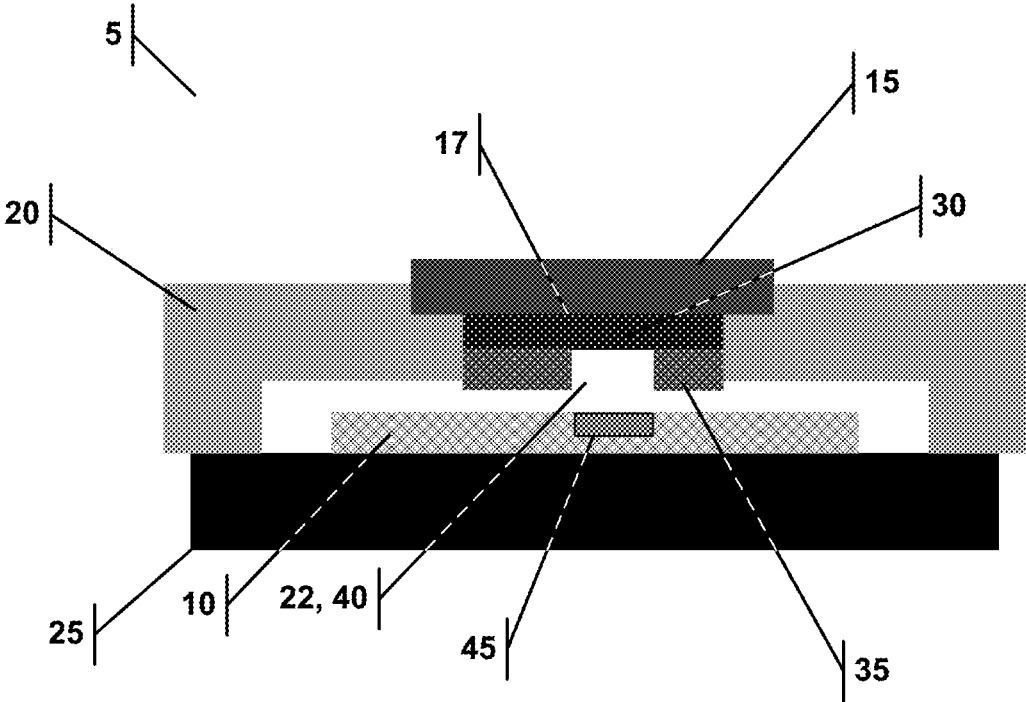

FIG 1D

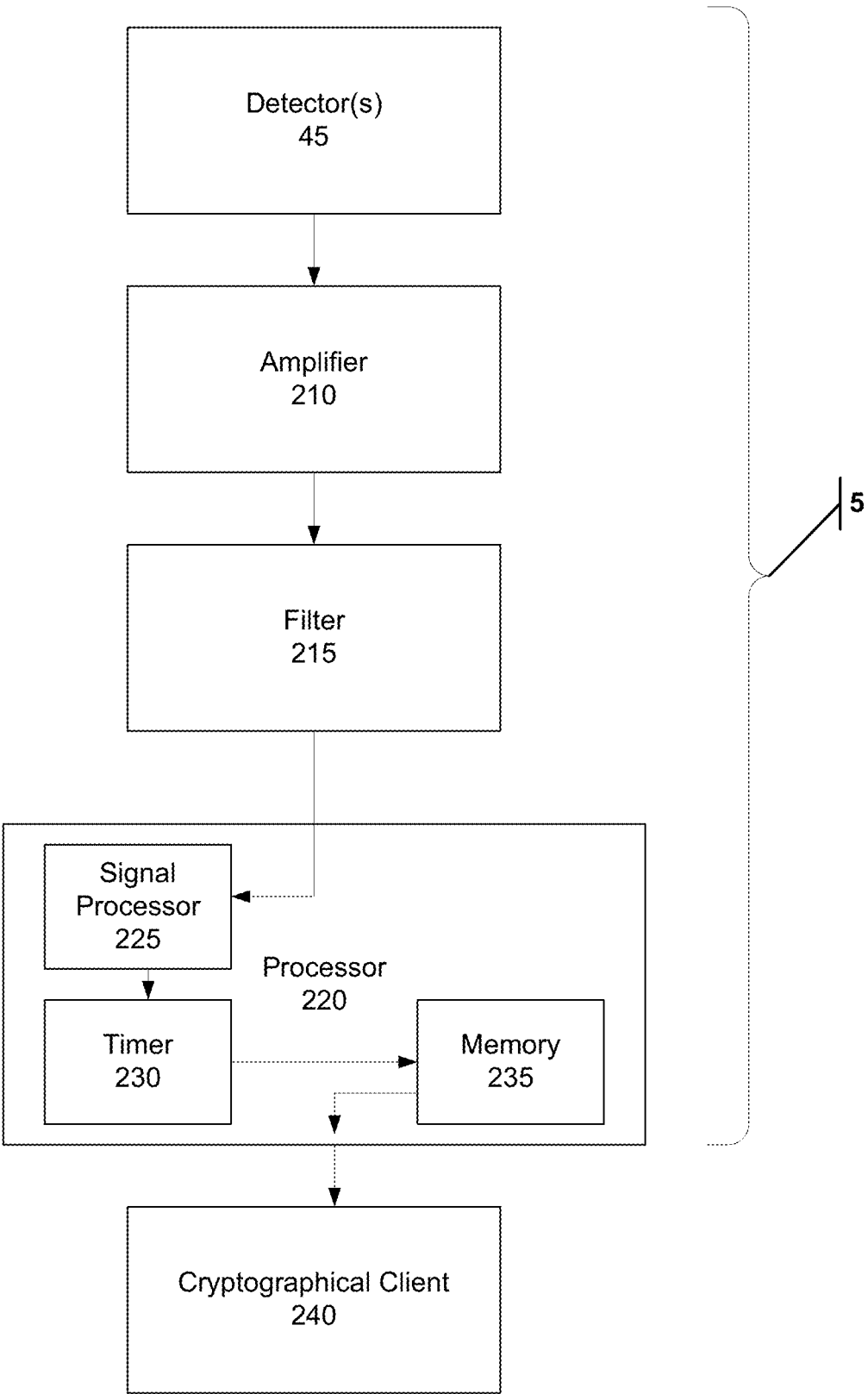

FIG 2

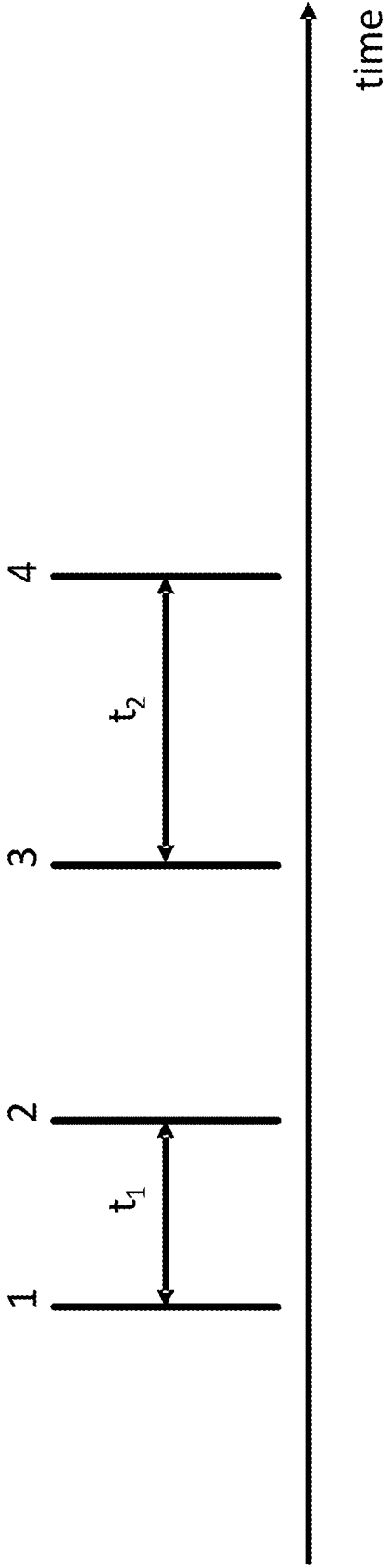

FIG 3A

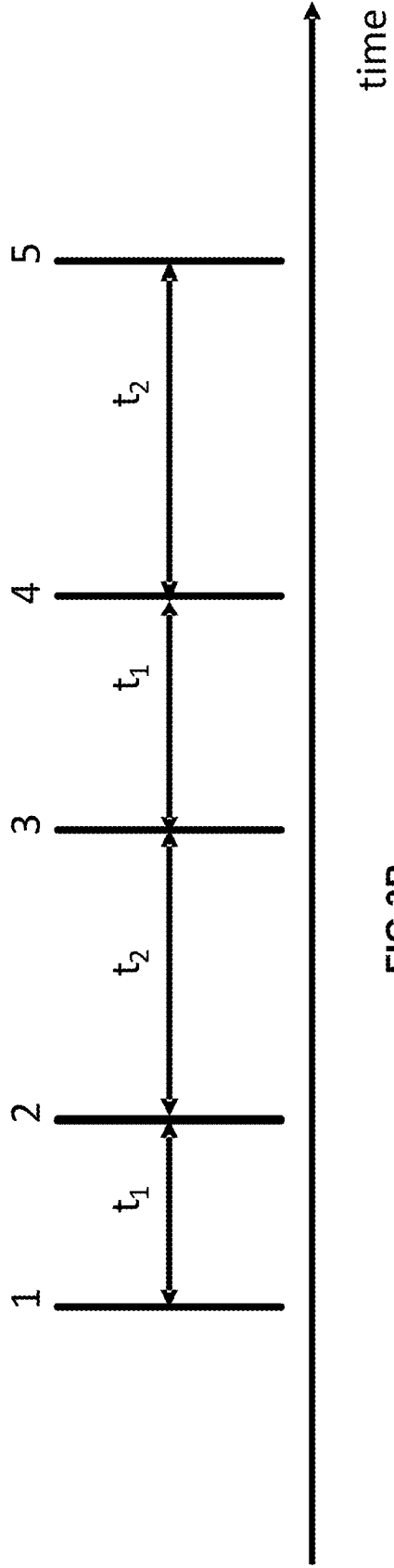

FIG 3B

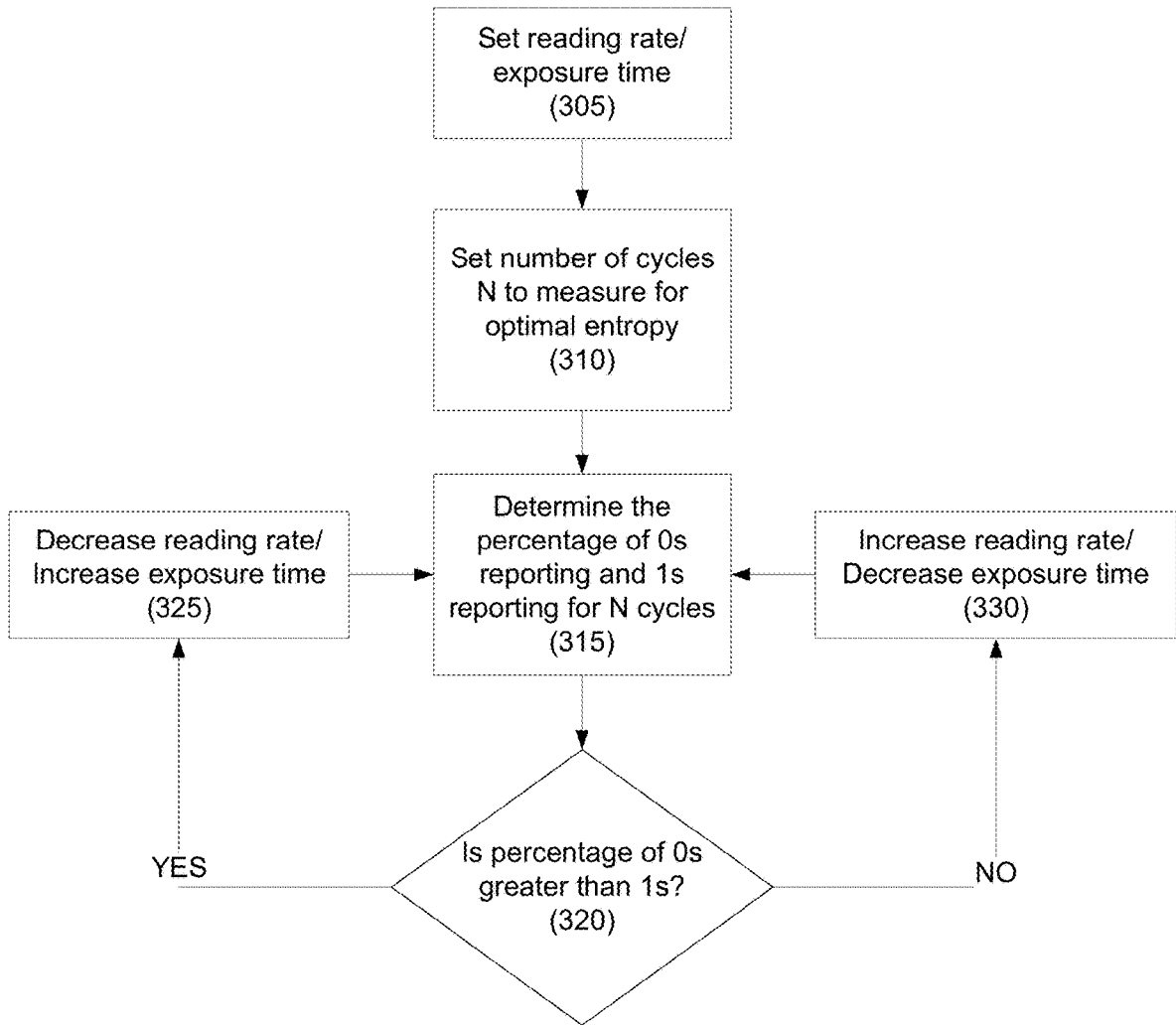

FIG 4
Method 300

**APPARATUS, SYSTEMS, AND METHODS
FOR BETA DECAY BASED TRUE RANDOM
NUMBER GENERATOR**

PRIORITY APPLICATIONS

This application claims priority to U.S. Provisional Application Ser. 62/984,528 filed on Mar. 3, 2020, titled "Method And Apparatus For Tritium-Based True Random Number Generator", and to U.S. Provisional Application Ser. No. 63/062,672 filed on Aug. 7, 2020, titled "Method And Apparatus For Beta Decay Based True Random Generator".

This application is also related to U.S. Provisional Application Ser. 62/655,172 filed on Apr. 9, 2018, titled "Apparatus, Systems, And Methods Comprising Tritium Random Number Generator", to U.S. Provisional Application Ser. 62/803,476 filed on Feb. 9, 2019, titled "Apparatus, Systems, And Methods Comprising Tritium Random Number Generator", and to U.S. application Ser. No. 16/273,365 filed on Feb. 12, 2019, titled "Apparatus, Systems, And Methods Comprising Tritium Random Number Generator", now U.S. Pat. No. 10,430,161.

Each of the patent applications, issued patents and other references discussed and/or cited herein is incorporated by reference as if fully set forth herein.

TECHNICAL FIELD

The present disclosure relates generally to true random number generators, and more specifically to random number generator technologies utilizing the spontaneous nickel isotope decay, as well as to apparatus, systems, and methods regarding same.

BACKGROUND

As opposed to pseudo random number generators based on numerical algorithms, there are true random number generator (TRNG) devices that depend on natural random processes: multiple bipolar switches, thermal noise, light scattering by dichroic mirrors, chaotic systems, and decay of radioactive nuclei. Some of these TRNG are listed in the provisional applications to which the present application claims priority, and those references are incorporated herein by reference as if fully set forth herein.

The decay of radioactive nuclei types is considered to be the most independent from environmental influences like temperature, pressure or acceleration. However, typical nuclear-based TRNGs require large size detectors to enable registration of particles emitted as a result of radioactive decays. Also, many nuclei used in such devices are highly radioactive and poisonous hence dangerous to humans if the device is broken.

Therefore, a safe and small TRNG that will not expose the user to dangerous levels of radiation would be advantageous. Such a TRNG can then be used in compact personal devices.

SUMMARY

The invention disclosed herein is a true random number generator (TRNG). The TRNG includes an enclosure defining a cavity and a cap covering the cavity and having a cap surface exposed to the cavity, the cap surface including radioactive nickel. An electronic sensor detects electrons within the cavity from the decay of the nickel and produces a signal for the detected energy. An amplifier is connected to

the sensor and is constructed to amplify the signal and then feeds the signal to a filter. A processor connected to the filter generates a true random number based on the signal. The true random number may be comprised of 256 bits, 512 bits or some other number of bits as required by an application.

The processor may be constructed to perform the following steps: (a) determine whether the signal represents decay events for nickel; (b) set a timer to determine the time period between several decay events; (c) based on the time periods in step (b), assign a value of a 0 or a 1; (d) store the value in a memory; (e) repeat steps (b)-(d) to result in a string of values; and (f) generate a true random number based on the string of values. Step (b) may further include determining a first time period T1 between a first pair of decay events and a second time period T2 between a second pair of decay events, in which case step (c) compares T1 to T2 and assigns the value based on the comparison of time lengths. The first pair of decay events and the second pair of decay events may share a common decay event. The processor may generate an array of true random numbers and may provide the array to a cryptographic client and then delete the delivered true random number from the memory.

The cavity, sensor, amplifier, filter, and processor are formed on an integrated circuit (IC). The nickel may be a result of salt electroplating of nickel on the cap. The amount of nickel is preferably sufficient to create at least one million decay events per second. The TNRG may include a timer with a clock frequency of at least 1 GHz. The amplifier may be a low noise charge-sensitive preamplifier or a pulse shaping amplifier.

The electronic sensor may be a sensor array, and the processor may perform the following steps: (a) assigning a 0 or a 1 based on the detection of electrons by some sensors (pixels) in the array (0 corresponds to no detection while 1 corresponds to detection of at least one electron); and (b) generating an array of true random numbers based on step (d) below. The processor may perform the following entropy adjustment sub-steps: (c) setting the reading rate of the sensors; (d) comparing the number of 0s reported by the sensor array to the number of 1s reported by the sensor array; and (e) adjusting the reading rate based on the comparison in step (d) so that numbers of 0s and 1s are equal within statistical error.

Additional aspects, alternatives and variations as would be apparent to persons of skill in the art are also disclosed herein and are specifically contemplated as included as part of the invention. The invention is set forth only in the claims as allowed by the patent office in this or related applications, and the following summary descriptions of certain examples are not in any way to limit, define or otherwise establish the scope of legal protection.

BRIEF DESCRIPTION OF DRAWINGS

The invention can be better understood with reference to the following figures. The components within the figures are not necessarily to scale, emphasis instead being placed on clearly illustrating example aspects of the invention. In the figures, like reference numerals designate corresponding parts throughout the different views and/or embodiments. Furthermore, various features of different disclosed embodiments can be combined to form additional embodiments, which are part of this disclosure. It will be understood that certain components and details may not appear in the figures to assist in more clearly describing the invention.

FIG. 1A is a cross-sectional view of a beta-decay detector in an enclosure, with a cap.

3

FIG. 1B is a cross-sectional view of a beta-decay detector, with a cap containing radioactive material.

FIG. 1C is a cross-sectional view of a beta-decay detector, with a cap containing radioactive material and a mask shielding some part of the radioactive material.

FIG. 1D is a cross-sectional view of a beta-decay detector fully assembled.

FIG. 2 is a flow diagram of the various components that may be placed on the integrated circuit.

FIG. 3A illustrates the four pulse per random bit schema.

FIG. 3B illustrates the two pulse per random bit schema.

FIG. 4 illustrates an entropy adjustment sub-steps/method used with an array-based detector.

DETAILED DESCRIPTION OF EXAMPLE EMBODIMENTS

Reference is made herein to some specific examples of the present invention, including any best modes contemplated by the inventor for carrying out the invention. Examples of these specific embodiments are illustrated in the accompanying figures. While the invention is described in conjunction with these specific embodiments, it will be understood that it is not intended to limit the invention to the described or illustrated embodiments. To the contrary, it is intended to cover alternatives, modifications, and equivalents as may be included within the spirit and scope of the invention as defined by the appended claims.

In the following description, numerous specific details are set forth in order to provide a thorough understanding of the present invention. Particular example embodiments of the present invention may be implemented without some or all of these specific details. In other instances, process operations well known to persons of skill in the art have not been described in detail in order not to obscure unnecessarily the present invention. Various techniques and mechanisms of the present invention will sometimes be described in singular form for clarity. However, it should be noted that some embodiments include multiple iterations of a technique or multiple mechanisms unless noted otherwise. Similarly, various steps of the methods shown and described herein are not necessarily performed in the order indicated, or performed at all in certain embodiments. Accordingly, some implementations of the methods discussed herein may include more or fewer steps than those shown or described. Further, the techniques and mechanisms of the present invention will sometimes describe a connection, relationship or communication between two or more entities. It should be noted that a connection or relationship between entities does not necessarily mean a direct, unimpeded connection, as a variety of other entities or processes may reside or occur between any two entities. Consequently, an indicated connection does not necessarily mean a direct, unimpeded connection unless otherwise noted.

The following list of example features corresponds with FIGS. 1-4 and is provided for ease of reference, where like reference numerals designate corresponding features throughout the specification and figures:

- Packaged Integrated Circuit with Detector **5**
- Substrate with IC **10**
- Cap **15**
- Cap Surface **17**
- IC Enclosure **20**
- Cavity **22**
- IC Base **25**
- Radioactive Material **30**
- Masking **35**

4

- Masking Window or Void **40**
- Radioactivity Detector/Sensor **45**
- Amplifier **210**
- Filter **215**
- Processor **220**
- Signal Processor **225**
- Timer **230**
- Memory **235**
- Cryptographical Client **240**
- Method Used with Array of Detectors **300**

As opposed to pseudo random number generators based on numerical algorithms, there are many true random number generator (TRNG) devices that depend on natural random processes: multiple bipolar switches, thermal noise, light scattering by dichroic mirrors, chaotic systems, decay of radioactive nuclei. The latter group is considered to be the most independent from environmental influences like temperature, pressure or acceleration. However, typical nuclear-based TRNGs require large size detectors to enable registration of particles emitted as a result of radioactive decays. Also, many nuclei used in such devices are highly radioactive and poisonous, hence dangerous to humans if device is broken.

Various example embodiments of the present apparatus, systems, and methods demonstrate that by using gaseous tritium paired with suitable solid-state detector one can make a very compact device that can be incorporated into integrated circuit chip. Because of small amounts of radioactive material deployed, such an IC can be used inside consumer products like cell phones without endangering people even if the device is destroyed and radioactive material is released. Analog and digital circuits that need to be incorporated into proposed design of TRNG on IC chip can be easily manufactured with standard epitaxial, implantation and laser annealing procedures used throughout industry that makes solid state devices.

Various example embodiments of the present apparatus, systems, and methods demonstrate that ICs can be impregnated with a radioactive material during manufacturing. See, e.g., FIGS. 1A-1D. Even with a very small amount of radioactive nickel, each such chip can generate many thousands of random bits per second. Then these bits can be stored for later use in solid state memory incorporated inside the IC. Thus, such a standalone TRNG on chip can easily provide on demand thousands of multi-byte random numbers needed for encryption of communication channels (like voice or text messages) or for processes requiring plenty of random numbers (like simulations or gaming).

In the related patent, U.S. Pat. No. 10,430,161 entitled "Apparatus, Systems, And Methods Comprising Tritium Random Number Generator", the general idea of using gaseous tritium as a medium randomly generating nuclear decays that are detected by the on-chip electronic sensor is described. By measuring and comparing time delays between two pairs of such decays, random numbers (bits) are generated.

In this application, a different type of beta decay is disclosed. Searching BIPM "Tables of Radionuclides", only two nuclides were discovered that produce pure beta-minus decay (emission of an electron) in the range of energies below 512 keV and having reasonable half-life times of more than ten years. See M.-M. Bé et al. 2008 Bureau International des Poids et Mesures, Sevrés (France) BIPM-5 vol. 1-4 "Table of Radionuclides". The limitations are of interest because the generation of gamma rays by highly energetic electrons cannot be easily shielded, since gamma rays penetrate typical materials used for enclosures while

short-lived isotopes are not suitable for the manufacturing of integrated circuits that can be used for longer than just a few years. Tritium, which we described as the source of randomness in U.S. Pat. No. 10,430,161, is one of the number of such nuclides, having an average energy of emitted electrons of about 5.7 keV (max energy about 18 keV) and a half-life time of about 12.3 years (about 4500 days). The problem with that isotope is that its gaseous form is very permeable and is hence hard to contain. In the related provisional U.S. Application Ser. 62/984,528 entitled "Method And Apparatus For A Tritium-Based True Random Number Generator", the use of tritiated water is disclosed possibly in the form of a gel that can be used to cover a radiation detector.

Another nuclide found in our search that fulfills the criteria is Nickel isotope with atomic number 63 (symbol ^{63}Ni). This isotope also emits only low energy electrons (average energy 17.4 keV, max energy about 67 keV) and has a half-life time of about 98.7 years. This nuclide decays to a stable ^{63}Cu , and it is produced by bombarding ^{62}Ni with neutrons, typically inside a nuclear reactor. The natural abundance of ^{62}Ni is about 3.6%. Hence, it is possible to have this isotope enriched by e.g. centrifugation before neutron irradiation, thus making production relatively easy, cf D. F. Williams et al. 1993 Oak Ridge National Laboratory TM-12399 "Recovery and Purification of Nickel-63 from HFIR-irradiated Targets". ^{63}Ni is available commercially, since it is used as a standard for calibration of medical and other beta detectors. Such standards are manufactured with different radioactivities by depositing thin layers containing nickel on various materials. Having ^{63}Ni as a salt (e.g. nickel chloride) allows for covering metal parts (foils, plates) with a precise amount of radionuclide by controlling the thickness of an electroplated nickel (current and time process control). All the above suggests that ^{63}Ni is a perfect candidate for a radiation source to be used in a true random number generator built into an integrated circuit.

The natural radioactivity of 1 mol of ^{63}Ni weighting 63 grams is half of the Avogadro's number over 98.7 years, or about 3×10^{23} decays in 3.1×10^9 seconds or about 10^4 decays per second. Since the density of nickel is about 8.9 g/cm^3 , the volume of ^{63}Ni needed to obtain 1 million decays per second, a number considered practical for a true random number generator, is less than 0.65 micrograms. These calculations do not include the geometric factor applied later on due to radiation being emitted in the whole sphere around each nuclei. With the market cost of 1 gram of ^{63}Ni being less than \$100,000.00, the amount of ^{63}Ni needed for the above-mentioned number of 1 million decays per second will cost less than \$0.07. The dose of radiation received by a human person (if all that amount of nickel is digested and absorbed by the body) is equal to about 23% of US natural background dose (about 0.7 mSv/year vs. 3.1 mSv/year for US natural background). This makes TRNG based on ^{63}Ni made as per this patent application very safe indeed. These numbers are presented in the Appendix. This is encouraging because a very small amount of metallic nickel-63 is required for each random number generator, and that will make manufacturing cost-effective and simple.

Electrons emitted in the spontaneous decay of ^{63}Ni that have on average the energy of 17.4 keV can be easily detected by PIN diode (P and N regions being heavily doped semiconductors with intrinsic semiconductor region sandwiched between them) or by typical CCD (Charge-Coupled Device) circuit; both these devices can be easily incorporated in a design on specialized IC with TRNG. FIG. 1A illustrates such a packaged IC design 5 that includes an

enclosure 20 that defines a cavity 22, and a cap 15 covering the cavity 22. The IC includes an IC base 25, a substrate with IC 10, and a detector/sensor 45. The cap 15 has a surface 17 that is exposed to the cavity 22. As shown in FIG. 1B, the cap 15 has a cap surface 17 that includes a radioactive material 30. The detector/sensor 45 detects electrons within the cavity 22 stemming from the decay of the radioactive material 30 and produces a signal for the detected energy. This detector/sensor 45 may be a PIN diode formed by the N-type silicon and P-type silicon on an intrinsic silicon substrate. A CCD may also be used as the detector. Other types of electronic sensors may be used, including, as a non-limiting example, a CMOS electronic sensor. FIG. 1D illustrates the assembled packaged integrated circuit 5.

The cap 15 may be made from any metal, electroplated to the desired radioactivity on one side, and prepared at the very end of the manufacturing process. This allows for different components to be assembled in different manufacturing plants and to be put together quickly in the last stages of IC manufacturing. The cap 15 covered with an amount of nickel 30 emitting about 1 million electrons every second will not be harmful to humans even though electrons emitted from such a source have larger energies than those emitted by tritium. Such a source will have an activity of about 0.27 μCi . 18 keV electrons are completely stopped by the outer part of the skin (10 to 40 microns thick). See M. J. Berger and S. M. Seltzer 1982 National Bureau of Standards NBSIR 82-2550 "Stopping Powers and Ranges of Electrons and Positrons". The introduction of radionuclides inside the body (like swallowing the cap) would result in a very mild radiation hazard that would amount to the dose of about 70 mrem—Annual Limit for Intake (ALI) is about 5 rem. See Appendix B to 10 CFR Part 20 www.nrc.gov/reading-rm/docollections/cfr/part020/part020-appb.html.

The range of 17.4 keV electrons in the air (or in some other inert gas like nitrogen) is about 6 mm hence the cap 15 with the radioactive material 30 does not need to be touching the substrate 10 of the IC 5 or the detector 45. It is sufficient to separate the radioactive material 30 from the detector 45 by a distance of less than about 1 mm, and still most of the emitted electrons will hit the detector. By varying the thickness of the electroplated nickel, the number of decays per second can be easily controlled. The area of the detector can also control this number. For example, a detector with an area of 0.56 mm^2 (e.g. 750 microns by 750 microns PIN diode with a surface that can be partially covered with an electron-blocking mask if the production requires it to be larger) and an active layer of about 2 microns of ^{63}Ni would produce more than 1 million counts per second if the geometric factor of about 0.07 is considered due to electrons flux being emitted into a full sphere around each nucleus. Due to the absorption of electrons in the electron-producing material, only a fraction of electrons emitted into a conical section of about 30° would be able to reach the detector 45, which is a flat surface outside of the sphere of emission. We used the formula for the fraction of the surface of a spherical sector of the sphere with the angle Φ measured from the center of the cone to its side:

$$(1 - \cos \Phi) / 2 \quad \text{Eq. 1.}$$

To prevent radiation damage of the integrated circuit that contains an embedded detector, the area of ^{63}Ni that can emit electrons may be limited so that only electrons destined to reach the detector will be open, while other portions of the ^{63}Ni layer on the cap will be covered by at least 100 microns of a masking material that absorbs electrons with energies smaller than 100 keV or so. Such a modification of the cap

is presented in FIG. 1C. The cap **15** has a layer of radioactive material **30** and a masking **35**, with a window or void **40** that corresponds to the area covered by the detector **45**. The masking **35** can be easily manufactured by either selectively spraying paint or by attaching a piece of foil with a void **40**. By carefully placing such a mask over the radioactive material **30** deposited on the cap **15**, the radiation exposure of other parts of the integrated circuit can be limited, especially if a passive area will be left around the detector **45**. An accuracy of about 0.25 mm will be enough in such a construction to effectively shield the rest of the integrated circuit from the electrons emitted by the source of randomness.

The detector **45** may be included on an IC **5**, which may further include an amplifier **210** (such as a low noise charge-sensitive preamplifier and pulse shaping amplifier), a filter **215**, and a processor **220**, as shown in FIG. 2. A cryptographic client **240** may optionally also be on the IC.

The following is a method for converting random nickel decays resulting in emission of electrons sensed by PIN diode or sensed by a CCD-type built-in on-chip detector **45** (discussed above) into a true random number:

1. After each decay of a nickel nuclei, one electron with an average energy of about 17.4 KeV is emitted.
2. Each such electron creates a pulse of electrons in the detector **45** with a very typical time profile that enables detection of just that event and not the other possible types of energetic ionizing particles hitting the detector **45**.
3. The analog pulse from the detector **45** is amplified by the amplifier **210**. The amplifier **210** may have a pre-amplifier.
4. The amplified signal from the amplifier **210** is filtered by the digital filter **215**.
5. The filtered signal is processed by the processor **220** to determine if the signal corresponds to the electron emitted in a decay of nickel and not by other energetic ionizing particle(s). The processor **220** may include a signal processor **225** that performs this function.
6. If the signal is indeed an electron emitted in the decay, then the processor **220** starts a timer **230**, which may also be part of the processor **220**. The timer **230** may optimally be at a clock frequency of the order of several GHz (several times 10^9 per second). Because electron pulses will be detected on average every microsecond (10^{-6} seconds or between on average several thousand clock ticks), one would have enough accuracy to detect differences of randomness of appearances of pulses in time.
7. Steps 1-6 are repeated to detect a second pulse from subsequent decay, which triggers the processor **220** to stop the timer **230**.
8. The value of the timer **230** is stored in the memory **235**. This is shown as T1 in FIG. 3A.
9. The next two pulses result in another timer value (T2; FIG. 3A) to be stored into the memory **235**. To generate T1 and T2, four pulses are used in FIG. 3A.
10. Two numbers (T1 and T2) stored in memories are compared—if first is larger, then the system creates a bit with the value 1; in the other case the value is zero (0). (This schema can be inverted as well). These bit values are stored into the memory **235**. In the very rare situation that the two numbers (T1, T2) are exactly same, the whole sequence is discarded. So for each random bit, four pulses are used.
11. Steps 1-10 are repeated, typically several hundred thousand times per second.

12. The system generates multibyte numbers, typically 256 bits or 512 bits long, and these are stored in the memory bank for further use by the cryptographic client **240** of the chip, providing long (large) random numbers needed for the encryption of communication channels.

13. After a number is used by the cryptographic client **240**, the FILO system (first in, last out) moves to the other number while the process described above adds more numbers to the memory **235** until it is filled. In such case of filling the whole memory bank, numbers kept longest in the memory **235** are expunged to make space for new numbers generated by the system. This capability makes the system much more resistant against hacking etc.

It should be noted that the system may not use four pulses per random bit. Instead, the system may be constructed as shown in FIG. 3B, where the timer resets at each pulse detection and is always counting. The benefit to this system is it only requires three pulses per random bit. But the two time periods are somewhat dependent on each other because they are linked by a pulse event, so the resulting string of bits may not be as random as the schema provided in FIG. 3A, and it may require randomization; see below.

To increase the efficiency of random number generation and to use simple electronic components, instead of measuring and comparing the time between detection of two pairs of electrons, it was suggested by several authors, including Patuleanu et al. 2017 Proc. Romanian Acad. series A, vol. 18, 389-402 “True Random Number Sequences From Gamma-Decay Using Four Extraction Methods”, that measuring random times between two successive decays can produce 3 bits from the least significant digits of the measurement. This means that from one million decays per second about 1.5 Mbits per second of randomness can be extracted. The actual number of generated bits will be lower due to the randomization procedure, cf. J. von Neumann 1951 Res. Nat. Bur. Stand. Appl. Math. Series 3, 36-38 “Various Techniques Used In Connection With Random Digits”, that is necessary to remove possible bias resulting from the dead time of the system counting events and other non-random processes involved. The modern version of this normalization uses three bits instead of two, thus increasing the efficiency of the process. See, e.g., B. Škorić 2015 Lecture notes 2IMS10 Technical University Eindhoven (Holland) “Physical Aspects Of Digital Security”.

Instead of using a single detector, the integrated circuit **5** may include an array of detectors, akin to a typical CCD optical matrix. The system may implement entropy adjustment sub-steps/method **300** in FIG. 4 to read the state of all pixels of such an array, and from that reading, to create a random number. For example, the integrated circuit **5** may have a detector **45** with a 10×10 array, capable of producing a 100 bit number. Random numbers may be generated directly from this array without the need of timing schema just discussed. The processor would assign a 1 or a 0 based on the signal received from each sensor in the array (electron hit or not), and those values can be strung together to generate an array of true random numbers. The process is like randomly dropping sand grains on the checkerboard.

But to ensure that the array-based TRNG is indeed random and has an optimal entropy, the system should confirm that the pixels are reporting 0 and 1 hits at the same probability of 50% to maximally increase entropy. In other words, adding all the 1s in a 10×10 array should on average equal 50, and adding all the 0s should also on average equal 50. If the reporting is not at the 50/50 optimal threshold, then

the system can increase or decrease registration time (decreasing or increasing the number of readings per second; the exposure time changes inversely, i.e. increasing number of readings decreases exposure time and vice versa). In this scheme, multiple hits of electrons of the same pixel will still

count as one hit. This method 300 of self-adjustment may be implemented in the processor 220: if the number of zeroes in a given readout is smaller than half of the total number of detectors used, then the system should increase the reading time (lower number of readings per second) and conversely, if the number of zeros larger than half of the total number of the detectors will result in shortening of the reading time (more readings per second). Such a feed-back method should converge quickly, thus wasting only a few reading cycles due to a random rate of decays that is constant with an average over time of several reading cycles, hence producing high-quality bits in a simple system that does not need a very accurate clock and pulse detection.

The method 300 first sets a reading rate/exposure time 305, and then sets a number of cycles 310 that will be used for quality control. From the readings within the cycle, the 0's are summed and compared to the sum of 1's in step 315. Ideally these numbers should be the same, but if they deviate with the percentage of 0s begin greater than 1s, then the system increases the reading rate/exposure time in step 325 by a similar percentage. Otherwise the system decreases the reading rate/exposure time in step 330.

The memory can supply the necessary number of bytes (bits) on demand for e.g. secure random encryption of communication channels (i.e., cryptographical client 240) of the device in which this specialized IC is mounted or for random processes required by simulations, modelling and gaming. Additional software testing of random number sequences, like method 300, may be built into IC chip to allow for real time quality control of random character of bits generated. If parts of the sequence do not pass test(s), such a sequence would be removed and never used as an output, or, as in method the 300, the reading rate of the detector can be adjusted to maintain optimal entropy. This type of proofing further improves the random character of the sequences that are being generated by the chip.

Various example embodiments of the present apparatus, systems, and methods provide the ability to manufacture TRNG ICs on the standard semiconductor production line, the only difference being that the packaging should leave as calculated above the detector of the size of about 0.5 mm² and a cap of the enclosure with electroplated nickel-63 shielded by the mask with the similar shape and positioned over detector. Otherwise, the produced ICs will be very similar in design and other characteristics to other ICs typically used in the manufacturing of consumer goods because electrons emitted during decay of nickel will not be able to penetrate protective materials on IC. The range of 18 keV electrons in a material like plastic is less than 3 micrometers. The packaging will be shielding the embedded detector from any external radiation of comparable or even much higher energies. Even if such high energy particles will pass through the packaging enclosure, they will generate different type of pulses and these can be differentiated by filtering from 18 keV pulses that are being used to generate random numbers.

Any of the suitable technologies, materials, and designs set forth and incorporated herein may be used to implement various example aspects of the invention, as would be apparent to one of skill in the art.

Although exemplary embodiments and applications of the invention have been described herein including as described above and shown in the included example Figures, there is no intention that the invention be limited to these exemplary embodiments and applications or to the manner in which the exemplary embodiments and applications operate or are described herein. Indeed, many variations and modifications to the exemplary embodiments are possible as would be apparent to a person of ordinary skill in the art. The invention may include any device, structure, method, or functionality, as long as the resulting device, system or method falls within the scope of one of the claims that are allowed by the patent office based on this or any related patent application.

APPENDIX

Density of ⁶³ Ni	63 g/mol	
Half-life	98.7 years	
	3,112,603,200 sec	
Need for TRNG	1,000,000 decays/sec	
	1 decay/ μ sec	
Radioactivity	1,000,000 Bq	
	2.70 * 10 ⁻³ Ci (with e ⁻ energy 17.4 keV per decay)	
Dose per body	2.23 * 10 ⁻¹⁰ J/(kgs) for 80 kg body	
	7.02 * 10 ⁻³ Gy/year	
	0.70 mSv/year	natural US background
		E _{US} = 3.1 mSv/year
		23% of US yearly natural background dose (if whole amount of nickel absorbed in body)
⁶³ Ni for 10 ⁶ decays/sec	6.51 * 10 ⁻⁷ g	
Cost of ⁶³ Ni needed	\$0.07 (⁶³ Ni costs less than \$100,000/gram)	
Detector size	0.56 mm ²	0.75 mm x 0.75 mm
Active layer thickness	2.0 μ m	
Volume of active ⁶³ Ni	0.0011 mm ³	
Mass of ⁶³ Ni needed	10.0 μ g	
Counts	1.03 * 10 ⁶ counts/sec with geometrical factor	
	0.07 included	

The invention claimed is:

1. A true random number generator (TRNG) comprising: an enclosure defining a cavity over the surface of an integrated circuit (IC); a cap covering the cavity with a cap surface exposed to the cavity, the cap surface comprising: radioactive nickel; and a mask applied over a portion of the radioactive nickel and constructed to limit the amount and direction of electrons emitted by the radioactive nickel into the cavity; wherein the IC comprises: an electronic sensor positioned at a distance across the cavity from the cap surface, the electronic sensor constructed to align with a void in the mask so as to detect electrons emitted by the radioactive nickel within the cavity and to produce a signal for the detected electrons; an amplifier connected to the electronic sensor and constructed to amplify the signal; a filter connected to the amplifier constructed to filter the signal; a processor connected to the filter, the processor constructed to generate a true random number based on the signal; wherein the mask at least partially shields the amplifier, filter and processor from electrons emitted by the radioactive nickel.

11

2. The TRNG of claim 1, wherein the processor constructed to perform the following steps:
 - a. determine whether the signal represents decay events for nickel;
 - b. set a timer to determine a time period between decay events;
 - c. based on the time periods in step (b), assign a value of a 0 or a 1;
 - d. store the value in a memory;
 - e. repeat steps (b)-(d) resulting in a string of values; and
 - f. generate a true random number based on the string of values.
3. The TRNG of claim 2, wherein step (b) further comprises, determining:
 - a first time period T1 between a first pair of decay events;
 - a second time period T2 between a second pair of decay events;
 wherein step (c) further comprises comparing T1 to T2 and assigning the value based on the comparison.
4. The TRNG of claim 3 wherein the first pair of decay events and the second pair of decay events share a common decay event.
5. The TRNG of claim 1, wherein the mask is at least 100 microns thick and absorbs electrons with energies smaller than 100 keV.
6. The TRNG of claim 1, wherein the processor generates an array of true random numbers.
7. The TRNG of claim 6, wherein the processor provides the array of true random numbers to a cryptographic client; and deletes the delivered true random number from the memory.
8. The TRNG of claim 7, wherein the array of true random number provided is the oldest in the array.
9. The TRNG of claim 6, wherein when the memory is full, the processor deletes the oldest one in the array of true random numbers.
10. The TRNG of claim 1, wherein the true random number is comprised of 256 bits or 512 bits.
11. The TRNG of claim 1, wherein the radioactive nickel is of sufficient quantity to create at least one million decay events per second.
12. The TRNG of claim 1, comprising a timer has a clock frequency of at least 1 GHz.
13. The TRNG of claim 1, wherein the amplifier comprises a low noise charge-sensitive preamplifier or a pulse shaping amplifier.
14. The TRNG of claim 1, wherein the electronic sensor is a sensor array.
15. The TRNG of claim 14, wherein the processor is constructed to perform the following steps:

12

- a. assigning a 0 or a 1 based on the detection from each of sensors in the array;
 - b. generating an array of true random numbers based on step (a).
16. The TRNG of claim 15, wherein the processor is constructed to perform the following entropy adjustment sub-steps:
 - c. setting a reading rate of the sensor array;
 - d. comparing a number of 0s reported by the sensor array to a number of 1s reported by the sensor array;
 - e. adjusting the reading rate based on the comparison in step (d).
 17. A personal electronic device comprising:
 - a true random number generator comprising:
 - an enclosure defining a cavity over the surface of an integrated circuit (IC);
 - a cap covering the cavity with a cap surface exposed to the cavity, the cap surface comprising:
 - radioactive nickel; and
 - a mask applied over a portion of the radioactive nickel and constructed to limit the amount and direction of electrons emitted by the radioactive nickel into the cavity;
 wherein the IC comprises:
 - an electronic sensor positioned at a distance across the cavity from the cap surface, the electronic sensor constructed to align with a void in the mask so as to detect electrons emitted by the radioactive nickel within the cavity and produce a signal for the detected electrons;
 - an amplifier connected to the electronic sensor and constructed to amplify the signal;
 - a filter connected to the amplifier constructed to filter the signal;
 - a processor connected to the filter, the processor constructed to generate a true random number based on the signal;
 wherein the mask at least partially shields the amplifier, filter and processor from electrons emitted by the radioactive nickel,
 - a cryptographic client adapted to receive the true random number.
 18. The personal electronic device of claim 17, wherein the true random number is used to encrypt a communication channel, to render computer simulations, or to render computer gaming.
 19. The personal electronic device of claim 17, wherein the mask is at least 100 microns thick and absorbs electrons with energies smaller than 100 keV.

* * * * *